



Baltic Sea Region
Programme 2007-2013

Part-financed by the European Union
(European Regional Development Fund
and European Neighbourhood and
Partnership Instrument)

Co₂olBricks

WP5 Education and Economic Promotion

Shading the windows

Educational product: New lecture material for training modules dealing with knowledge and skills how to apply suitable methods of energy efficient refurbishment of historic constructions and how innovation can be combined with cultural heritage



Shading the windows

Target group: architecture, construction, energy audit students

Educational objectives: To give information about solar energy, traditional and innovative shading systems.

This measure can help to save up to 7% of total energy used in building

Lecture course: 2 academic hours

References:

Yoo, Seung-Ho, and Heinrich Manz. "Available remodeling simulation for a BIPV as a shading device." *Solar Energy Materials and Solar Cells* 95.1 (2011): 394-397.

Lomanowski, Bartosz A., and John L. Wright. "Modeling fenestration with shading devices in building energy simulation: a practical approach." *11th International IBPSA Conference Glasgow, Scotland*. 2009.



Table of Contents

- Introduction
- Solar radiation
- Heat build-up and transfer
- Types of shading systems
- Lighting
- Shading systems in historic buildings
- Design and evaluation of shading systems
- Conclusion
- Bibliography

Introduction

Shading systems are designed to deal with solar radiation. Protection of the building's apertures is the first consideration in the design of shading systems. When designed well they may also protect the opaque surfaces, including the roof. Shading systems can help save energy by reducing:

- cooling loads in summer/heat loads in winter
- needed artificial lighting (redistribute daylight).

Depending on the amount and location of fenestration, reductions in annual cooling energy consumption of 5% to 15% have been reported. Shading systems can also improve user visual comfort by controlling glare and reducing contrast ratios.

While the cooling load may be reduced by shading, any associated reduction of lighting in the space may lead to a higher artificial lighting load. Therefore the design of shading systems should consider concurrently heat rejection in summer/heat capture in winter, daylighting and ventilation needs.

Solar radiation

At an average distance of 150 million kilometers from the Sun, the outer atmosphere of Earth receives approximately 1367 W/m² of insolation. This varies by around ±2% due to fluctuations in emissions from the Sun itself as well as by ±3.5% due to seasonal variations in distance and solar altitude.

The radiation from the Sun is spread over a wide frequency range. The total energy received from the Sun is divided ca. 50/50 visible/invisible range. As Figure 1 shows:

- 46%–47% represents visible range with wavelength of 350nm to 780nm
- 45% is in the near-infrared range of 780nm to 5000nm
- 8%–9% is ultraviolet radiation.

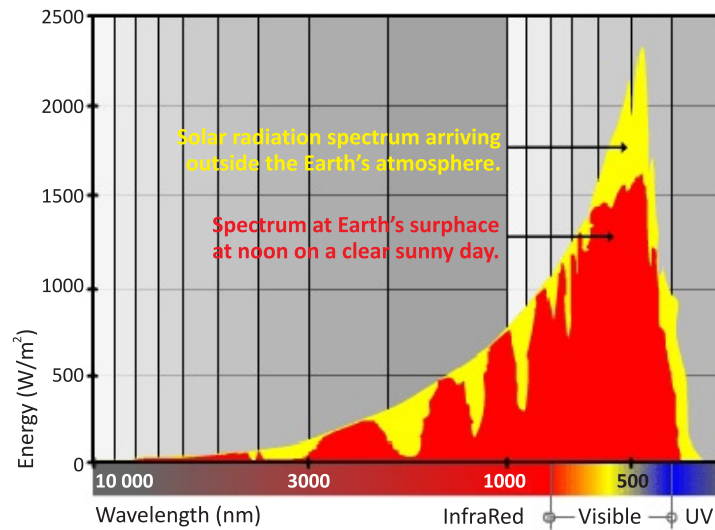

Fig.1 — Spectral content of incident solar radiation

As solar radiation passes through the Earth's atmosphere, some of it is absorbed and scattered (25%) by air molecules, small airborne particles, water vapour, aerosols and clouds whilst the rest arrives somewhere on the Earth's surface.

It just happens that most of the particles in the atmosphere that are responsible for scattering are around 500nm in size. As radiation with longer wavelengths simply ignores these particles, shorter wavelength radiation tends to be scattered more. This is what makes the sky appear blue — as longer wavelength red and yellow light pass almost directly through whilst blue light is bounced about all over the place.

Near the surface solar radiation can be divided into:

- *direct solar radiation*, that passes directly through to the Earth's surface. Even in a relatively cold climate, direct solar radiation can be a source of extreme local discomfort, equivalent to a 1000W electric bar radiator for every square metre of exposed window
- *diffuse radiation* is the radiation that has been scattered out of the direct beam. It is the scattered component that makes the sky look bright and provides the ambient diffuse daylighting
- *reflected radiation*, which amount depends on the nature of the actual surface — fresh snow can reflect up to 95% whilst desert sands reflect 35–45%, grasslands 15–25% and dense forest vegetation 5–10%.

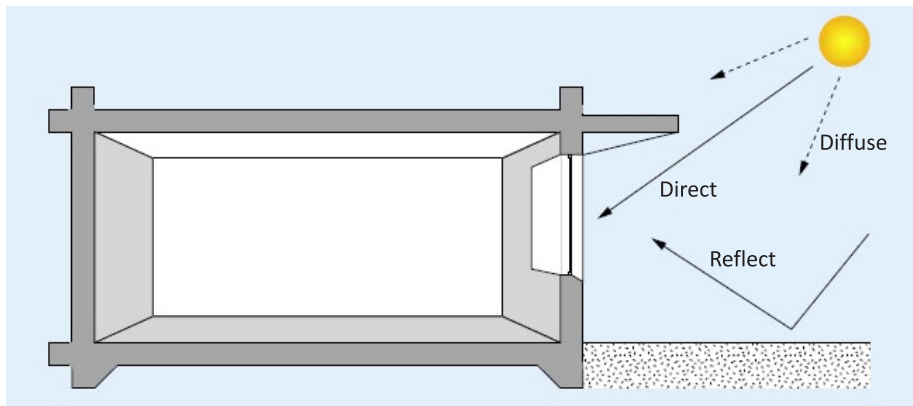

Fig. 2. Components of solar radiation

Heat build-up and transfer

Materials absorb sun energy in wide spectrum, retain some of this energy as heat and partly emit it as long-wave radiation (the greater the temperature of an object, the shorter the wavelength of its radiant emissions). In the temperature range (10–100°C) surfaces of materials that have been warmed by the sun emit in far-infrared range. Biological metabolisms also generate heat which radiates from the skin surface at these wavelengths. The gained heat can be transferred by:

- conduction
- convection
- radiation.

The most efficient method of heat transfer is *conduction*. The transfer occurs as the fast-moving molecules of the hot object bump into the slower-moving molecules of the cold object. The fast molecules give up some of their energy, slowing down, and this energy goes into speeding up (and thus heating up) the slow molecules. The exact speed of this transfer therefore depends on the molecular density of each material. Metals, being quite dense, are the most effective heat conductors whereas gasses are among the worst.

A slower method of heat transfer is *convection*, which occurs in fluids or gases. A cool fluid in contact with a warm solid will heat up through conduction. As it heats, the fluid will expand slightly and its density will be reduced. As the warmer fluid is in contact with the colder fluid, the weight of the colder section of fluid forces the warmer section to rise, setting up a convective current. Because material must actually be moved, convection is less efficient than conduction.

In case of *radiation*, the heat moves through space as an electromagnetic wave without the assistance of a physical substance. This is how the Sun's heat reaches the Earth. Radiative heat is transferred directly into the surface of any object it hits (unless it is highly reflective), but passes readily through transparent materials such as air and glass.

Types of shading systems

Shading systems may be designed to protect transparent as well as opaque surfaces, which means that, shading the building facades and roof can also reduce unwanted heat build-up, particularly when these elements are not insulated and conduction heat flows through the façade into the building.

Shading systems can be:

- fixed — cannot change over the course of a day to account for the movement of the Sun
- adjustable/retractable — operated by occupants or automation. They respond better to the movement of the Sun and allow better control of diffuse radiation.

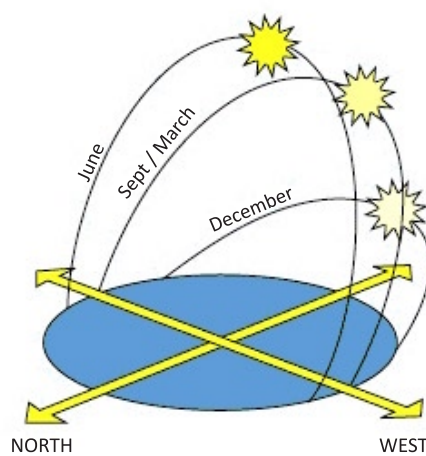

Fig. 3. Summer, winter, equinox sunpath

Solar control and shading can be provided by:

- overshadowing from:
 - vegetation (trees, vines, shrubs)
 - urban morphology (shading by neighboring buildings)
 - exterior elements such as overhangs or vertical fins
- combined daylight & shading devices, that perform double role of protection against solar radiation and redistribution of light (examples: light shelves, Venetian blinds)
- advanced glazing systems (AGS), e.g. tinted/reflective/"low-e"/responsive glass etc. In many cases use of such glasses can save significant amounts of energy. However, if specified or used incorrectly they can actually add to the heat loads in a building
- other shading technologies (e.g. transparent insulation materials (Aerogel)).

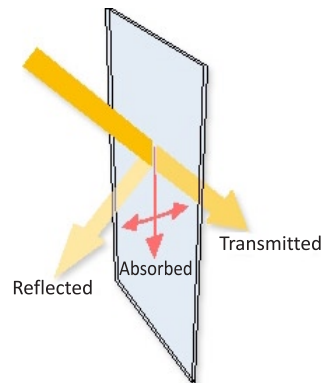

Fig. 4. The three major components of sunlight when it hits a pane of glass

When sunlight hits a pane of glass, it is split into three major components: reflected, absorbed and transmitted through. The reflected and transmitted components remain as visible and short-wave infrared wavelengths. The energy from the absorbed component heats up the pane of glass and is radiated back out into the environment as heat (long-wave radiation). In an urban environment, using a highly reflective glazing simply makes the reflected solar radiation someone else's problem. With specified restrictions on reflectivity, all that is left for manufacturers is to increase the absorbed component. Thus the plethora of tinted and spectrally selective glazing available. Such glasses do work — in that they reduce the transmission of direct solar radiation — however, if used incorrectly you will end up gaining almost as much heat by long-wave radiation as you would have by short-wave if you had used normal glass. Tinted windows, for example, can become very warm (up to 50°C). Some of this heat is then radiated to the interior space, causing discomfort to anyone nearby.

Shading devices may be located at the

- external or
- internal face of the façade, or
- within double- and triple-glazed windows.

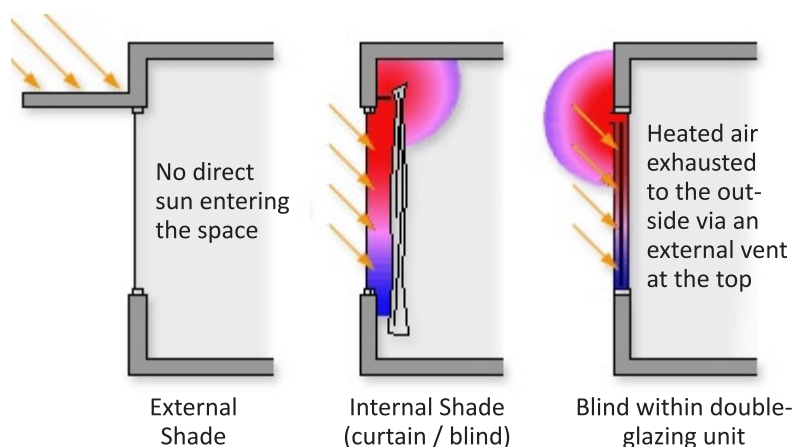

Fig. 5. Location of shading devices

External shading devices are particularly effective against direct solar radiation. The diffuse and reflected components, due to their wider angles of incidence, are more difficult to control and are thus more effectively controlled by internal or mid-pane devices. External shades intercept and dissipate (by convection) most (up to 95%) of the direct radiation before it reaches the building façade. As a result solar heat gain is prevented from passing into the building, minimizing ventilation requirements and reducing cooling loads. If a controllable system is installed, adjustable louvres track the position of the sun, thereby optimizing the avoidance of overheating. Equally, in winter the louvres may be adjusted in such a way that the building benefits from the heat from the sun, and they can be closed at night reducing heat loss. Similarly, daylight levels can be enhanced, and levels of glare reduced. Where possible you should always use external shading devices.

In case of internal shading devices the solar radiation passes through the glass and hits the shade, effectively heating it up. Because of this the effectiveness of most internal shades in preventing heat gain to the internal space is limited. Internal devices protect occupants against the immediate effects of direct sunlight and glare, but most of the heat absorbed is released into the room by convection (traditional interior blinds or drapes). Internal devices with a reflective external coating reduce this effect by reflecting some of the transmitted radiation to the outside. As simulation in Figure 6 shows, when using internal shades, it is advisable to install sealed pelmet to prevent vertical circulation of air.

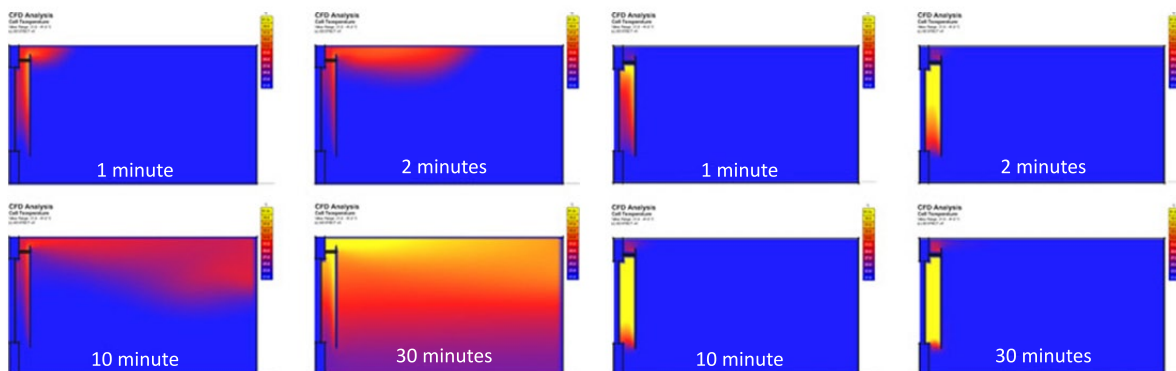

Fig. 6. Propagation of hot air without sealed pelmet (left) and with installed sealed pelmet (right)

Mid-pane devices when accompanied by effective ventilation to the outside combine the advantages of external and internal shades. Heat gains are dissipated to the outside, but the shades are protected from the severity of the outdoor climate. Mid-pane devices are particularly effective in controlling glare.

Lighting

Some shading devices (light shelves, advanced glazing systems, blinds, reflective louvers, external fins, etc.) are able to redirect and redistribute natural light thorough a space, i.e. reduce glare at the window area and increase illuminance at the rear.

Although overall illuminance in a space is important, it is the distribution of light in the field of vision that determines the quality of the lighting environment. When light is evenly distributed throughout the space, people are less inclined to switch on the lights even when the actual light levels are lower than ideal.

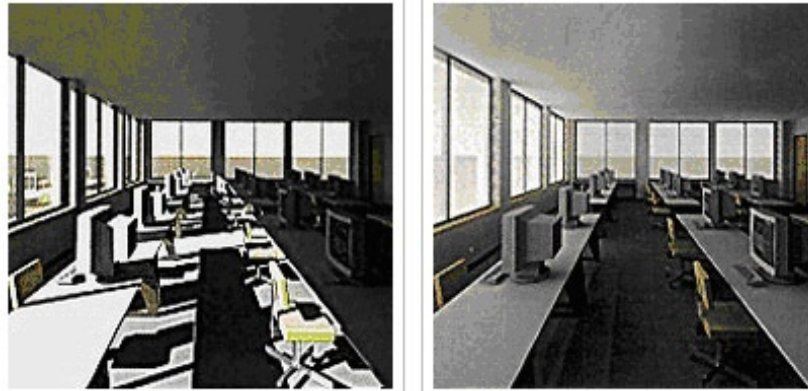

Fig. 7. Difference between a sunlit (left) and daylit (right) space

Shading systems in historic buildings

The first split system air conditioner was produced by General Electric in 1929. Before that people have to rely on traditional systems to control climate inside the building. Also the values of buildings were mainly esthetical where shape, proportions, material and daylight were the main elements. The following shading systems can be considered traditional:

- overshadowing by urban design and vegetation
- external shutters or blinds
- awnings
- horizontal beam overhangs.

The researchers from The Edinburgh World Heritage claim, that in historic buildings with single glazing, shutters and full length curtains could be as effective as double glazing, when preventing heat from leaving the room. In Figure 8, windows with the shutters and curtains closed show up in the images in a deep blue colour, demonstrating little heat is escaping.

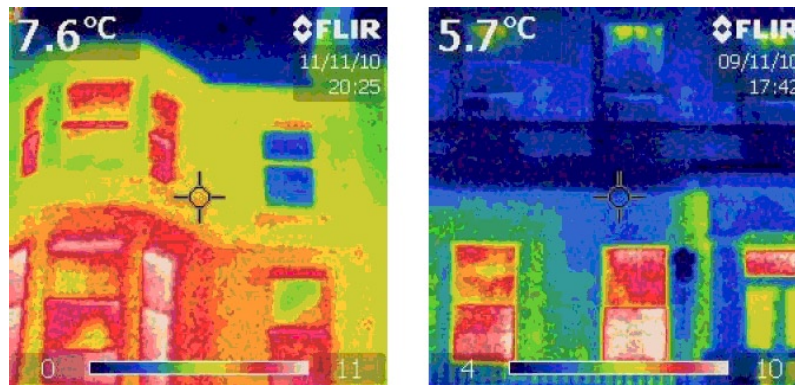

Fig. 8. Shutters and blinds on the top right window (left), shutters on top floor windows (right)

Today, in historic buildings advanced glazing systems can replace traditional strategies for shielding a room from unwanted sunlight. In hot climates, spectrally selective glasses admit visible light wavelengths while reflecting unwanted infrared wavelengths. In cold climates, “low-e” coatings are of interest. These coatings reduce radiative heat losses by reflecting heat back into the building. The bottom-line effect is an increase in the insulating value of the window. For even better performance, gaps between the layers of multiglazed windows can be filled with gases—such as argon, krypton, or xenon — that have better insulating properties than air.

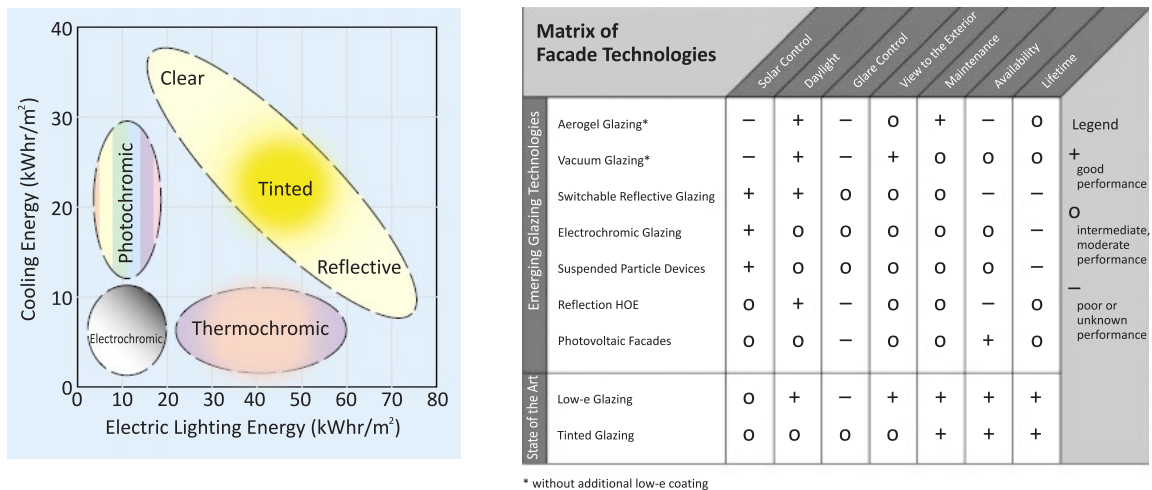

Fig. 9. Simple comparison of glazing systems

Other modern shading systems can be retrofitted into historic buildings. The Norrlandsgatan 20 project (see Fig. 10) in Stockholm — newly developed office space in the roof area — is an example where a variable, high-tech solar shading system with an ultra modern look is integrated elegantly into a historic building. Geometrically optimized and active large louvre blades are able to automatically adjust to the position of the Sun, the time of year and the rotation of the Earth.

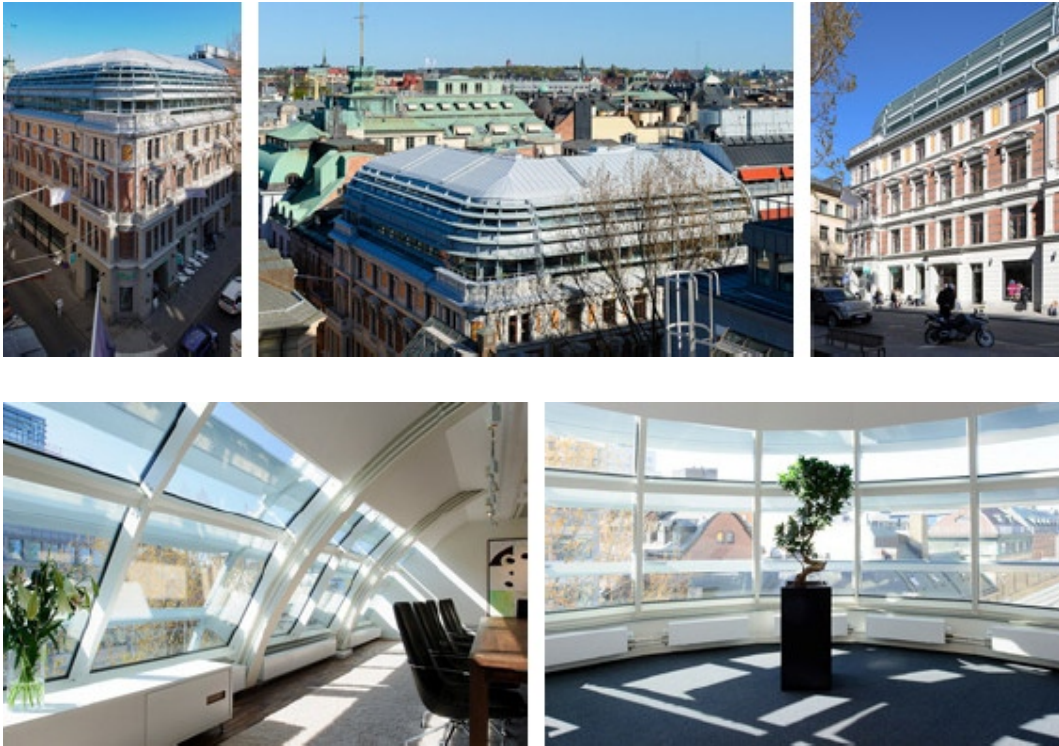

Fig. 10. Integration of large louvre blades in historic building

Design and evaluation of shading systems

The design of effective shading devices will depend on the solar orientation of a particular building façade and the position of the Sun in the sky. The Sun's position on the sky vault is defined in terms of altitude and azimuth angles, using solar time.

- The altitude angle is the angle of the sun above the horizon (the zenith = 90°).
- The north-based azimuth angle is measured in the horizontal plane from North.

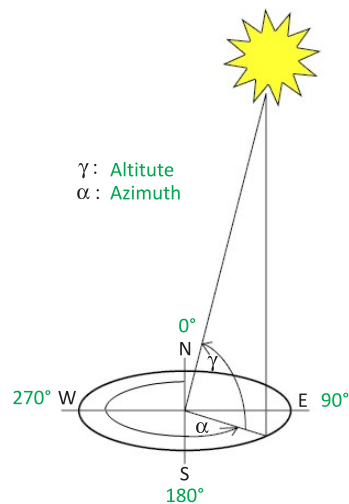

Fig. 11. Sun's position

When designing an external shading system, the sun's movement and influence can be predicted using a number of methods. There are three main types of manual sunpath diagram: the equidistant chart, the orthographic projection and the stereographic projection. The stereographic diagram is the most widely used. Shadow masks created using the stereographic projection are a very useful tool in designing shading devices and assessing shadow impact.

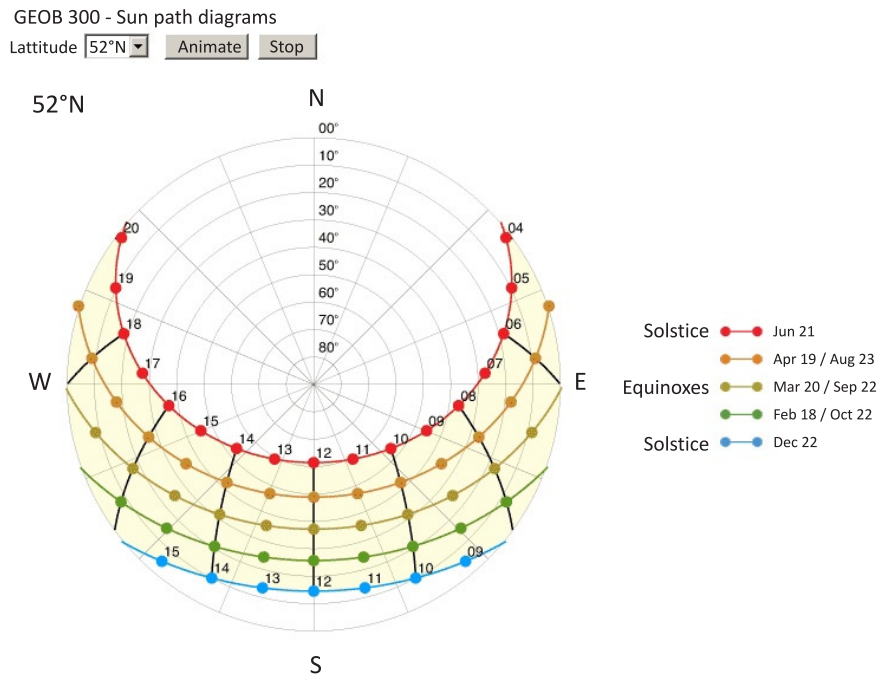

Fig. 12. Stereographic sunpath diagram (Latitude 52° North)

There is a number of 3D computer modeling software is readily available that include algorithms for the Sun's movement throughout the year for most latitudes and can be used for visualizing the overshadowing impact of neighbouring buildings as well as designing shading devices (e.g. Autodesk Ecotect, Revit, Vasari, 3ds Max, Daysim, Radiance, etc.).

At present various methods with different approaches are used for evaluating performance of shading devices, based on calculation of solar gain to the space, or internal light levels. The *shading coefficient* is a highly useful concept for evaluation purposes. It is the ratio of the total solar radiation entering through the combination glass-shading element to that entering a single unshaded glass window. It should be considered as an approximate value, as the position of the sun, and the proportion of the direct and diffuse solar radiation incident on the shading system, changes throughout the day.



When designing and evaluating shading system a reference to the following international standards can be made:

- ISO 18292:2011 Energy performance of fenestration systems for residential buildings - Calculation procedure
- ISO 15099:2003 Thermal performance of windows, doors and shading devices - Detailed calculations
- ISO 10077:2012 Thermal performance of windows, doors and shutters.

It is necessary to watch that thermal (reducing overheating) and visual (reducing glare) comfort requirement are met. The international standard for thermal comfort is

- ISO 7730:2005 Ergonomics of the thermal environment - Analytical determination and interpretation of thermal comfort using calculation of the PMV and PPD indices and local thermal comfort criteria.

Conclusion

The choice of shading strategy is determined by building and site location, orientation, building type and use, sky conditions (the direct, diffuse and reflected solar radiation components) and other light sources such as intrusive street lighting. The overall cooling, heating and daylighting strategies adopted in the design phase also influence the choice of shading system. In historic buildings correctly designed simple devices, are often as effective as hi-tech systems.

Shading devices should be able to moderate or control direct, diffuse and reflected solar radiation, and glare, whilst ensuring that day lighting and natural ventilation are not excessively reduced.

Bibliography

- Shading systems - Solar shading for the European climates [Austin Stack, John Goulding and J. Owen Lewis]
- <http://sustainabilityworkshop.autodesk.com>
- <http://wiki.naturalfrequency.com>
- Harmony and Change - Schueco ALB large louvre blades used in a historic project
- Energy Efficiency for Edinburgh's World Heritage Site - Final report
- <http://www.nps.gov/tps/sustainability/energy-efficiency/weatherization/shading-devices.htm>
- <http://www.shadingsystemsinc.com/blog>